

**COUNTY OF SAN MATEO
PLANNING AND BUILDING DEPARTMENT**

DATE: September 10, 2014

TO: Planning Commission

FROM: Planning Staff

SUBJECT: EXECUTIVE SUMMARY: Consideration of a Resource Management Permit and a Grading Permit for (1) the construction of improvements to an existing driveway involving grading, and (2) installation of two water storage tanks and a fire hydrant, all to meet the requirements for serving an existing residence as mandated by the County Fire Authority, on a 97.5-acre parcel located at 5755 Alpine Road (within the Alpine Road County Scenic Corridor), in the unincorporated La Honda area of San Mateo County.

County File Number: PLN 2014-00046
(Midpeninsula Regional Open Space District)

PROPOSAL

The applicant, Midpeninsula Regional Open Space District (MROSD), is requesting the necessary permits to: (1) make required improvements to an existing 950-foot long driveway leading from Alpine Road to an existing residence, and (2) install two water storage tanks (4,900- and 2,500-gallon size) and fire hydrant and associated piping for fire suppression purposes. Both the road improvements and water tank installation stem from the County Fire Authority's (Cal-Fire) review of and final approval for the reinstated building permit (BLD 2011-00958) for the existing residence. The specific road improvement components include: driveway turnout, turnaround, widening, asphaltic paving and associated stormwater drainage along portions of the driveway. The project site is located within the Alpine Road County Scenic Corridor.

RECOMMENDATION

That the Planning Commission approve the Resource Management Permit and Grading Permit, County File Number PLN 2014-00046, by making the required findings and adopting the conditions of approval listed in Attachment A.

SUMMARY

The applicant is proposing to make improvements along an existing driveway to an existing single-family house and install water storage tanks and fire suppression improvements to the property.

The project parcel is owned by MROSD and is currently closed to the public. The parcel contains a house built in 1976, which is located approximately 1,000 feet south and west of a staging area (parking, restroom and trails) that was previously approved and completed in 2013 (PLN 2011-00372).

The proposed project complies with the applicable San Mateo County General Plan Policies, Resource Management (RM) Zoning District Regulations, and Grading Regulations.

RJB:fc – RJB0755_WFU.DOCX

**COUNTY OF SAN MATEO
PLANNING AND BUILDING DEPARTMENT**

DATE: September 10, 2014

TO: Planning Commission

FROM: Planning Staff

SUBJECT: Consideration of a Resource Management Permit, pursuant to Section 6313 of the San Mateo County Zoning Regulations, and a Grading Permit, pursuant to Section 8600 of the San Mateo County Ordinance Code, for (1) the construction of improvements to an existing driveway involving grading, and (2) installation of two water storage tanks and a fire hydrant, all to meet the requirements for serving an existing residence as mandated by the County Fire Authority, on a 97.5-acre parcel located at 5755 Alpine Road (within the Alpine Road County Scenic Corridor), in the unincorporated La Honda area of San Mateo County.

County File Number: PLN 2014-00046
(Midpeninsula Regional Open Space District)

PROPOSAL

The applicant, Midpeninsula Regional Open Space District (MROSD), requests the necessary permits to: (1) make improvements to an existing 950-foot long driveway leading from Alpine Road to an existing residence, and (2) install two water storage tanks (4,900- and 2,500-gallon size) and fire hydrant and associated piping for fire suppression purposes. Both the road improvements and water tank installation stem from the County Fire Authority's (Cal-Fire) review of and final approval for the reinstated building permit (BLD 2011-00958) for the existing residence. The specific road improvement components include a driveway turnout, a turnaround, widening, asphaltic paving and associated stormwater drainage along portions of the driveway. The project site is located within the Alpine Road County Scenic Corridor.

RECOMMENDATION

That the Planning Commission approve the Resource Management Permit and Grading Permit, County File Number PLN 2014-00046, by making the required findings and adopting the conditions of approval listed in Attachment A.

BACKGROUND

Report Prepared By: Rob Bartoli, Project Planner, Telephone 650/363-1857

Owner: Midpeninsula Regional Open Space District (MROSD)

Applicant: Zachary Alexander, MROSD

Location: 5755 Alpine Road, La Honda

APN: 080-380-030

Parcel Size: 97.5 acres

Existing Zoning: Resource Management (RM) District

General Plan Designation: Open Space

Existing Land Use: The project parcel is owned by MROSD and is currently closed to the public. The parcel contains a house built in 1976, which is located approximately 1,000 feet south and west of a staging area (parking, restroom and trails) that was previously approved and completed in 2013 (PLN 2011-00372).

Flood Zone: Zone X (area of minimal flood hazard, usually depicted on FIRMs as above the 500-year flood level), FEMA Panel 06081C0415E, effective date October 16, 2012.

Environmental Evaluation: California Environmental Quality Act (CEQA) Categorical Exemption, Section 15301 (Existing Facilities), Class 1.

Setting: The project parcel, part of the Russian Ridge Open Space Preserve, is located adjacent to and west of Alpine Road. The project parcel adjoins other parcels owned by MROSD which are part of the Preserve. Grazing and timber production occur on these lands. The surrounding landscape is characterized by a mix of grassland, oak woodland, and mixed evergreen forest habitat types. The subject driveway leading to the house exits off Alpine Road and traverses in a generally parallel direction downward along an average 33% slope. The driveway serves a house and garage, barn and horse paddock and corral. The driveway is located about 1,000 feet south of the primary access to the Preserve off Alpine Road (where a staging area, parking and trail improvements were built pursuant to previously approved planning permit).

Agricultural Use: The property is presently under a Williamson Act contract. The contract was non-renewed by the property owner and will expire on December 31, 2020. The Board of Supervisors approved a Williamson Act contract amendment to permit open space and public recreational use of the project parcel. The amended contracts were recorded on October 16, 2012. The improvements to the existing driveway and the installation of the water storage tanks will not require any amendments to the Williamson Act contract. The project site is not currently used for agricultural production or grazing, although an adjoining site under the same original contract is used for grazing. The site does not contain prime soils.

Chronology:

<u>Date</u>	<u>Action</u>
August 1975	- Parcel Map is recorded for subdivision resulting in the parcel's legal creation.
1976	- House constructed under Building Permit #A26451, but permit was never finalized. ¹ County Building Inspection Section records show that the house on the project parcel was completed after cancellation of the building permit for the residence.
2011	- MROSD purchases the property (formerly the Silva property) and adds the property to the 3,137-acre Russian Ridge Open Space Preserve.
July 14, 2011	- Applicant applies to reinstate and final Permit #A26451, under BLD 2011-00958, for the existing residence.
April 24, 2013	- Planning Commission approves RM and Grading permits (PLN 2011-00372) for MROSD's 20-space paved parking lot, 42-space unpaved special event parking area, entry gate, vault restroom, two trail connections and access to a viewing site and associated grading and signage, all to serve the Preserve. Condition of Approval No. 15 requires that the existing house on the parcel, whose building permit had expired, be either demolished or legalized. MROSD's choice to legalize the residence (per above-cited building permit) triggered Cal-Fire's requirements, which are the subject of this application.
November 2013	- Project improvements approved under PLN 2011-00372 are completed.

DISCUSSION

A. KEY ISSUES

1. Conformity with the General Plan

The County's General Plan designates the property for Open Space land use. Table 7.1P describes the primary feasible uses associated with this land use designation as "Resource management and production uses, ...

¹ Building Permit #A26451 was issued in 1976, in close proximity to revisions to the Resources Management Regulations (Ordinance No. 2347).

and recreation uses, including, but not limited to ... residential uses ...” Currently, the property contains a private single-family residence that is not accessible to the public and that is currently used as a residence for MROSD employees.

As proposed and conditioned, the project conforms to all applicable General Plan policies, with specific discussion of the following policies:

a. Vegetative, Water, Fish and Wildlife Resources Element

Policy 1.27 (*Regulate Development to Protect Sensitive Habitats*) calls to regulate land uses and development activities within and adjacent to sensitive habitats in order to protect critical vegetative, water, fish and wildlife resources; protect rare, endangered, and unique plants and animals from reduction in their range or degradation of their environment; and protect and maintain the biological productivity of important plant and animal habitats. Neither the existing driveway and its improvements, the location for two water tanks, nor the location between the driveway’s terminus and the house, is located in or near any sensitive habitat. The driveway improvements (which include widening and turnouts at some sections) and the two tanks will result in the removal of some brush and a number of trees of less than 12 inches in diameter.

b. Soils Resources Element

As proposed and conditioned, the project complies with policies that apply to grading activities, including Policy 2.23 (*Regulate Excavation, Grading, Filling, and Land Clearing Activities Against Accelerated Soil Erosion*), and Policy 4.25 (*Earthwork Operations*). These policies call for the County to regulate excavation, grading, filling, and land clearing activities to protect against accelerated soil erosion and sedimentation, encourage soil stabilization efforts, minimize grading operations in rural areas, and encourage contour grading rather than harsh cutting or terracing practices. Proposed grading is necessary to create the required turnouts, widening and turnaround as required by Cal-Fire for the access road to the house. Current Planning staff, Department of Public Works staff, and the Planning and Building Department’s Geotechnical Engineer have reviewed the proposed grading and erosion control plans (included in Attachment D) and have found the project, as proposed and conditioned, to comply with the County’s Grading Regulations (full discussion is included in Section A.3 of this report).

- (1) Compliance with erosion control guidelines (adopted as part of an existing Memorandum of Understanding with the Regional Water Quality Control Board (Water Board)).

- (2) Implementation of Best Management Practices for erosion and sediment control previously approved by the California Department of Fish and Game and Water Board and in use by the MROSD.
- (3) All work will be conducted during the dry season.
- (4) All exposed soil surfaces in the parking lot construction area would be seeded and mulched prior to the onset of the rainy season.

Staff has added Condition Nos. 6 and 8 to require the applicant to revise and comply with the Schematic Erosion Control Plan and comply with standard Best Management Practices (BMPs). Condition Nos. 7 and 11 require the applicant to submit the Stormwater Pollution Prevention Plan (SWPPP) for the project as required by the State and a detailed schedule of grading operations, prior to the commencement of grading.²

c. Visual Quality Element

Policy 4.21 (*Scenic Corridors*) calls for the protection and enhancement of the visual quality of scenic corridors by managing the location and appearance of structural development. The project site is located within the Alpine Road County Scenic Corridor. The subject driveway, due to its downward (ranging from 15 to 70 feet below the Alpine Road grade) and widening nature that traverses amidst dense intervening tree canopy and vegetation, is not visible from Alpine Road (except at its entry point). Likewise, the proposed tanks, located downhill and about 300 feet from Alpine Road amidst dense tree canopy, would not be visible. The proposed removal of minor brush and trees due to the driveway improvements will not diminish the screening the cited features provide.

Policy 4.24 (*Location of Structures*) requires the location, siting and design of all structures in the rural areas to carefully conform with the natural vegetation, landforms and topography of the site so that their presence is compatible with the pre-existing character of the site. Also, the policy calls for the location and design of structures to minimize the impacts of noise, light, glare and odors on adjacent properties and roads. The only new structures proposed are the two water tanks. Both would be partially submerged, with the 2,500- and 4,900-gallon tanks having a total height above grade of 8' 2" and 7' 9½", respectively. The two tanks will be of a dark green color.

² Commencement of project grading requires the issuance of a grading permit "hard card" by the County.

Policy 4.60 (*Roads and Driveways*) calls (1) for the design and construction of new roads, road improvements and driveways to be sensitive to the visual qualities and character of the scenic corridor, including such factors as width, alignment, grade, slope, grading and drainage facilities; (2) to limit the number of access roads connecting to a scenic road to the greatest extent possible; and (3) to share driveways where possible to reduce the number of entries onto scenic roads. The applicant proposes driveway improvements, as previously described, to the primary access to the existing house. No new driveway or road is proposed.

d. Rural Land Use Element

The project parcel adjoins other parcels owned by MROSD which are part of the Russian Ridge Open Space Preserve. Grazing and timber production occur on these lands. The proposed project will not impact these uses.

2. Conformity with Resource Management (RM) Zoning District Regulations

The project site is located within the Resource Management (RM) Zoning District. Pursuant to Section 6313 of the County Zoning Regulations, all development proposed for location within the RM District requires the issuance of an RM Permit; this requirement applies only to the proposed water tanks. However, the grading activities associated with the proposed driveway improvements are excluded from the RM definition of development where such grading and excavation operations are otherwise subject to regulations of the County Ordinance Code, Chapter 8, Regulations for Excavating, Grading, Filling and Clearing on Lands in Unincorporated San Mateo County. In this case, the driveway activities require a Grading Permit pursuant to those regulations, thus are exempt from RM Permit requirements.

The requirement of an RM Permit necessitates a review of the proposal against criteria outlined in Chapter 20A (*RM District Regulations*) and Chapter 20A.2 of the County Zoning Regulations (*Development Review Criteria*).

a. RM District Regulations

Per Section 6315(I), a single-family dwelling unit is a permitted use on the property. The residence, as previously cited in this report, was built legally in 1976, but never received a final inspection and approval (which will be resolved upon issuance and approval of BLD 2011-00958). As a condition to the final of the cited building permit, the project involves the installation of two water storage tanks, a fire hydrant, associated piping for fire suppression purposes, and grading

for improvements to the access driveway leading to the house. These elements, with the exception of grading, are subject to the development standards of the RM District. The structure complies with the required minimum setbacks (50-foot front setback, 20-foot rear and side setbacks), the 36-foot height limit, and a 30-foot minimum required setback from the main residence.

b. Development Review Criteria

The following is an analysis of project compliance with applicable Site Design, Water Resources, Cultural Resources Criteria and Primary Scenic Resources Criteria.

Site Design Criteria:

Criterion (a): Development shall be located, sited and designed to carefully fit its environment so that its presence is subordinate to the pre-existing character of the site and its surrounding is maintained to the maximum extent practicable. The area designated for the two water tanks is within close proximity to the existing road. Only a slight change in grade will need to occur to create a flat pad area for the two tanks. There is an existing retaining wall that will remain and support the new engineered fill needed for the new pad. The removal of some brush and a number of trees of less than 12 inches in diameter would occur as part of this project. Both tanks would be partially submerged, with the 2,500- and 4,900-gallon tanks having a total height above grade of 8' 2" and 7' 9½", respectively. The two tanks will be of a dark green color to blend into the surrounding vegetation.

Criterion (b): All roads, buildings and other structural improvements or land coverage shall be located, sited and designed to fit the natural topography and shall minimize grading and modification of existing landforms and natural characteristics. Primary Designated Landscape Features defined in the Open Space and Conservation Elements of the San Mateo County General Plan shall not be damaged. There are no Primary Designated Landscape Features within the area of the water tanks. Grading for the tanks shall be kept to a minimum.

Criterion (h): The development shall employ colors and materials which blend in with, rather than contrast with, the surrounding soil and vegetative cover of the site. Materials shall absorb light (i.e., dark, rough textured materials). Exterior lighting shall be minimized, and earth-tone colors of lights used (e.g., yellow, brown toned lights, rather than blue toned fluorescents). In grassland, or grassland/forest areas, all exterior materials shall be of the same earth and vegetative tones as the predominant colors of the site (as determined by on-site inspections). Highly reflective surfaces and colors are discouraged.

The two tanks will be of a dark green color and will be partially below grade. The project complies with this criterion and the criterion has been incorporated as Condition No. 14 of Attachment A.

Criterion (i): Wherever possible, vegetation removed during construction shall be replaced. Vegetation for the stabilization of graded areas or for replacement of existing vegetation shall be selected and located to be compatible with surrounding vegetation, and should recognize climatic, soil and ecological characteristics of the region. The project includes minimal vegetation removal, due to the disturbed and compacted condition of the site.

Criterion (j): Removal of living trees with trunk circumference of more than 55 inches measured 4½ feet above the average surface of the ground is prohibited, except as may be required for development permitted under this Ordinance, or permitted under the Timber Harvesting Ordinance, or for reason of actual or potential danger to life or property. No trees of this size are proposed for removal for the installation of the two water tanks or in conjunction with the driveway improvements. Condition No. 3 prohibits the removal of trees meeting the above criteria and any trees with a circumference of 38 inches or more located within 100 feet of Alpine Road.

Water Resources Criteria:

Criterion (d): Site preparation procedures and construction phasing shall be carefully controlled to reduce erosion and exposure of soils to the maximum extent possible. As previously discussed, staff has added Condition Nos. 6 and 8 to require the applicant to revise and comply with the Schematic Erosion Control Plan and standard Best Management Practices (BMPs).

Criterion (e): Projects shall utilize methods to maintain surface water runoff at or near existing levels. As proposed and conditioned (Condition No. 15), the project incorporates vegetated swales and other drainage features to comply with the requirements for stormwater treatment as contained in Provision C.3 of the National Pollutant Discharge Elimination System (NPDES) Municipal Regional Permit. Per Condition Nos. 27 and 28, the project shall demonstrate compliance with the Drainage Policy of the Department of Public Works.

Primary Scenic Resources Areas Criteria:

Criterion (a): Public views within and from scenic corridors shall be protected and enhanced, and development shall not be allowed to significantly obscure, detract from, or negatively affect the quality of

these views. Vegetative screening or setbacks may be used to mitigate such impacts. Development visible from scenic corridors shall be so located and designed as to minimize interference with ridgeline silhouettes. The subject driveway, due to its downward (ranging from 15 to 70 feet below the Alpine Road grade) and widening nature that traverses amidst dense intervening tree canopy and vegetation, is not visible from Alpine Road (except at its entry point). Likewise, the proposed tanks, located downhill and about 300 feet from Alpine Road amidst dense tree canopy, would not be visible.

Criterion (b): Clear cutting or removal of existing vegetation from rights-of-way is prohibited, except in those areas required for road and shoulder alignment or as required for reasons of safety, or permitted under Subsections (h) and (i). Condition No. 3 prohibits the removal of any trees with trunk circumference of more than 55 inches or any tree with a circumference of 38 inches or more which are located within 100 feet of Alpine Road. Condition No. 5 requires that, other than in the direct footprints of approved development (e.g., driveways, trail connections, and signage), clear cutting or removal of existing vegetation from rights-of-way is prohibited. Under this permit, existing vegetation (e.g., low-lying shrubs and tree limbs) may be removed within an approximate 4-foot wide swath along the project's border with Alpine Road, north of the proposed driveway, to improve stopping sight distance for southbound vehicles and corner sight distance for vehicles exiting the driveway.

3. Conformity with Grading Regulations

The project involves 885 cubic yards of balanced cut and fill, associated primarily with grading necessary for the widening of the driveway, creation of a required turnout and turnaround, and the installation of two water tanks. These improvements are all requirements from County Fire Authority (Cal-Fire). The project site is located within the Alpine Road County Scenic Corridor. Therefore, per Section 8604.3 of the Grading Regulations, the grading permit is subject to review by the Planning Commission. In order to approve this project, the Planning Commission must make the required findings contained in the Grading Regulations. The findings and supporting evidence are outlined below:

a. **That the project will not have a significant adverse effect on the environment.**

The proposed grading would occur within already disturbed areas to widen an existing driveway. Minimal grading would occur for the installation of the two water tanks. The removal of some brush and a number of trees of less than 12 inches in diameter would occur as part

of this project. No significant habitats or environmental resources would be altered.

- b. That the project conforms to the criteria of Chapter 8, Division VII, San Mateo County Ordinance Code, including the standards referenced in Section 8605.**

The project, as proposed and conditioned, conforms to the standards in the Grading Regulations, including timing of grading activity, erosion and sediment control, and air quality control. Condition No. 7 limits grading to the dry season (May 1 to September 30). Condition Nos. 6 through 11 ensure compliance with the County stormwater requirements. Condition No. 18 requires implementation of air quality measures. The project has been reviewed and approved with conditions by the County's Department of Public Works and the Planning and Building Department's Geotechnical Engineer.

- c. That the project is consistent with the General Plan.**

The General Plan land use designation for the property is Open Space. As proposed and conditioned, the project complies with applicable General Plan policies, as discussed in Section A.1 of this report.

After review and consultation with the applicant's geotechnical advisor, the County's Department of Public Works and the Planning and Building Department's Geotechnical Engineer believe the project can be completed without significant harm to the environment. Per the Geotechnical Engineer, Planning staff has added Condition No. 13 to Attachment A requiring the project's geotechnical consultant to observe grading and improvements at the site. Staff has determined that the project, as proposed and conditioned, conforms to the criteria for review contained in the Grading Regulations.

4. Compliance with Williamson Act Contract

The property is subject to the requirements of its Williamson Act contract. The property owner initiated non-renewal of the contract, which was recorded with the County Recorder's Office on October 18, 2011. Due to a nine-year phase-out period, the contract will expire on December 31, 2020. The terms of a Williamson Act contract are enforceable during the non-renewal process. The use of the Mindego Gateway property conforms to its contract terms due to long-term, ongoing grazing activities on the property (a large portion of the property is leased to a local rancher, Vince Fontana).

In April 2012, County staff determined that open space and public recreational uses conflict with the Williamson Act contract for the property,

which only permits agricultural uses and residential uses accessory to agricultural use. County staff informed the applicant that the conflict must be resolved prior to further processing of this permit application. Subsequently, MROSD applied for an amendment to its Williamson Act contract to permit open space and public recreational use of the project parcel, which was approved by the Board of Supervisors on September 25, 2012. The amended contract was recorded on October 16, 2012. The improvements to an existing driveway and the installation of two water storage tanks will not require any amendments to the Williamson Act contract.

B. ENVIRONMENTAL REVIEW

The project has been deemed to fall under CEQA Categorical Exemption, Section 15301 (Existing Facilities), Class 1. The proposed project will widen the existing driveway and add two water tanks to an already developed property with an existing single-family dwelling unit.

C. REVIEWING AGENCIES

County Planning and Building Department's Geotechnical Engineer
County Environmental Health Division
County Department of Public Works
County Building Inspection Section
California Department of Forestry and Fire Protection (Cal-Fire)

ATTACHMENTS

- A. Recommended Findings and Conditions of Approval
- B. Property Vicinity Map
- C. Aerial View of Site Plan for Entire Subject Parcel (5755 Alpine Road)
- D. Location Map Showing Area of Scenic Corridor
- E. Plans for the Driveway and Turnaround Improvements (includes survey, grading and drainage plan, and erosion control plan), received June 26, 2014

RJB:fc – RJB0756_WFU.DOCX

County of San Mateo
Planning and Building Department

RECOMMENDED FINDINGS AND CONDITIONS OF APPROVAL

Permit or Project File Number: PLN 2014-00046 Hearing Date: September 10, 2014

Prepared By: Rob Bartoli, Project Planner For Adoption By: Planning Commission

RECOMMENDED FINDINGS

Regarding the Resource Management Permit, Find:

1. That the project conforms with the development review criteria for the Resource Management (RM) District as contained within Chapter 20A.2 of the Zoning Regulations. As stated in Section A.2 of the staff report, the project, as proposed and conditioned, complies with the policies and objectives of the RM District, including development standards and Site Design, Water Resources, Cultural Resources, and Primary Scenic Resources Criteria. As proposed and conditioned, the project is designed to fit its environment, would replace removed vegetation and provide additional landscaping, improves stormwater drainage through bioswales and treatment, would not result in visual impacts to the Alpine Road County Scenic Corridor, and provides public access to recreational uses.

Regarding the Grading Permit, Find:

2. That the granting of the permit will not have a significant adverse effect on the environment. The proposed grading would occur within already disturbed areas to widen an existing driveway. Minimal grading would occur for the installation of the two water tanks. The removal of some brush and a number of trees of less than 12 inches in diameter would occur as part of this project. No significant habitats or environmental resources would be altered.
3. That the project conforms to the criteria of Chapter 8, Division VII, San Mateo County Ordinance Code, including the standards referenced in Section 8605. The project, as proposed and conditioned, conforms to the standards in the Grading Regulations, including timing of grading activity, erosion and sediment control, and air quality control. The project has been reviewed and approved by the County's Department of Public Works and the Planning and Building Department's Geotechnical Engineer.

4. That the project is consistent with the General Plan. The project, as proposed and conditioned, conforms to all applicable General Plan policies, including policies that encourage the preservation and management of sensitive habitats, regulate grading activities, protect scenic corridors, and promote parks and recreational opportunities. As proposed and conditioned, the project would protect biological resources, incorporates conditions of approval which protect soils resources through the minimization of grading and use of proper erosion control, protects views from the Alpine Road County Scenic Corridor by protecting existing vegetation and planting new landscaping, promotes additional public recreation opportunities, and enhances the safety of staff and patrons.

RECOMMENDED CONDITIONS OF APPROVAL

Current Planning Section

1. The approval applies only to the proposal as described in this report and materials submitted for review and approval by the Planning Commission on September 10, 2014. Minor adjustments to the project may be approved by the Community Development Director if they are consistent with the intent of and in substantial conformance with this approval.
2. These permits shall be valid for two (2) years from the date of this approval. If the building permit has not been issued within this time period, these permits will expire. An extension to these permits will be considered upon written request and payment of applicable permit extension fees submitted to the Current Planning Section a minimum of sixty (60) days prior to expiration.

Tree Protection, Vegetation Removal, and Revegetation:

3. This permit does not authorize the removal of any trees with trunk circumference of more than 55 inches or any tree with a circumference of 38 inches or more which are located within 100 feet of Alpine Road. Such activity would require application for and issuance of a separate Resource Management (RM) Permit. All trees not approved for removal under this permit shall be protected during grading operations. Prior to any grading activity on the project site, the property owner shall implement the following tree protection plan:
 - a. The property owner shall establish and maintain tree protection zones throughout the entire length of the project.
 - b. Tree protection zones shall be delineated using 4-foot tall orange plastic fencing supported by poles pounded into the ground, located as close to the driplines as possible while still allowing room for construction/grading to safely continue.

- c. The property owner shall maintain tree protection zones free of equipment and materials storage and shall not clean any equipment within these areas.
- d. Should any large roots or large masses of roots need to be cut, the roots shall be inspected by a certified arborist or registered forester prior to cutting.
- e. Any root cutting shall be monitored by an arborist or forester and documented.
- f. Roots to be cut should be severed cleanly with a saw or topers.
- g. Normal irrigation shall be maintained, but oaks should not need summer irrigation.

The above information shall be on-site at all times.

- 4. Project-related land disturbance and construction shall remain within the project area, as shown on approved plans.
- 5. Other than in the direct footprints of the approved development (e.g., driveways, and water tanks), clear cutting or removal of existing vegetation from rights-of-way is prohibited. Under this permit, existing vegetation (e.g., low-lying shrubs and tree limbs) may be removed within an approximate 4-foot wide swath along the project's border with Alpine Road, north of the proposed driveway, to improve stopping sight distance for southbound vehicles and corner sight distance for vehicles exiting the driveway.

Grading and Erosion Control:

- 6. No grading activities shall commence until the property owner has been issued a grading permit (issued as the "hard card" with all necessary information filled out and signatures obtained) by the Current Planning Section. Grading activities shall be limited to the dry season (May 1 to September 30).
- 7. As the project involves over 1 acre of land disturbance, the property owner shall file a Notice of Intent (NOI) with the State Water Resources Board to obtain coverage under the State General Construction Activity National Pollutant Discharge Elimination System (NPDES) Permit. A copy of the project's NOI, Waste Discharger Identification (WDID) Number, and Stormwater Pollution Prevention Plan (SWPPP) shall be submitted to the Current Planning Section and the Building Inspection Section, prior to the issuance of the grading permit "hard card."
- 8. Prior to any land disturbance and throughout the grading operation, the property owner shall implement the erosion control plan, as prepared and signed by the

engineer of record and approved by the Planning Commission and as revised per Condition No. 9. Revisions to the approved erosion control plan shall be prepared and signed by the engineer and submitted to the Community Development Director for review and approval.

9. Prior to the issuance of the grading permit “hard card,” the property owner shall submit to the Current Planning Section, subject to review and approval by the Community Development Director, a revised erosion control plan to include the following:
 - a. The location of the earth stockpile and proposed measures to prevent erosion of the stockpile throughout the duration of on-site storage.
 - b. Designated location of grading and construction vehicle parking, using aggregate over geotextile fabric, surrounded by slatted chain-link fencing to provide screening from the Alpine Road County Scenic Corridor.
 - c. The chain-link enclosing the temporary storage area shall be slatted to provide screening from the Alpine Road County Scenic Corridor.
10. Prior to issuance of the grading permit “hard card,” the property owner shall submit a schedule of all grading operations to the Current Planning Section, subject to review and approval by the Current Planning Section. The submitted schedule shall include a schedule for winterizing the site. If the schedule of grading operations calls for the grading to be completed in one grading season, then the winterizing plan shall be considered a contingent plan to be implemented if work falls behind schedule. All submitted schedules shall represent the work in detail and shall project the grading operations from initiation through to completion.
11. The property owner shall adhere to the San Mateo Countywide Stormwater Pollution Prevention Program “General Construction and Site Supervision Guidelines,” including, but not limited to, the following:
 - a. Delineation with field markers clearing limits, easements, setbacks, sensitive or critical areas, buffer zones, trees, and drainage courses within the vicinity of areas to be disturbed by construction and/or grading.
 - b. Protection of adjacent properties and undisturbed areas from construction impacts using vegetative buffer strips, sediment barriers or filters, dikes, mulching, or other measures as appropriate.
 - c. Performing clearing and earth-moving activities only during dry weather.
 - d. Stabilization of all denuded areas and maintenance of erosion control measures continuously between October 1 and April 30.

- e. Storage, handling, and disposal of construction materials and wastes properly, so as to prevent their contact with stormwater.
 - f. Control and prevention of the discharge of all potential pollutants, including pavement cutting wastes, paints, concrete, petroleum products, chemicals, wash water or sediments, and non-stormwater discharges, to storm drains and watercourses.
 - g. Use of sediment controls or filtration to remove sediment when dewatering site and obtain all necessary permits.
 - h. Avoiding cleaning, fueling, or maintaining vehicles on-site, except in a designated area where wash water is contained and treated.
 - i. Limiting and timing application of pesticides and fertilizers to prevent polluted runoff.
 - j. Limiting construction access routes and stabilization of designated access points.
 - k. Avoiding tracking dirt or other materials off-site; cleaning off-site paved areas and sidewalks using dry sweeping methods.
 - l. Training and providing instruction to all employees and subcontractors regarding the Watershed Protection Maintenance Standards and construction Best Management Practices.
 - m. Additional Best Management Practices in addition to those shown on the plans may be required by the Building Inspector to maintain effective stormwater management during construction activities. Any water leaving the site shall be clear and running slowly at all times.
 - n. Failure to install or maintain these measures will result in stoppage of construction until the corrections have been made and fees paid for staff enforcement time.
12. It shall be the responsibility of the engineer of record to regularly inspect the erosion control measures for the duration of all grading remediation activities, especially after major storm events, and determine that they are functioning as designed and that proper maintenance is being performed. Deficiencies shall be immediately corrected, as determined by and implemented under the observation of the engineer of record.
13. For the final approval of the grading permit, the property owner shall ensure the performance of the following activities within thirty (30) days of the completion of grading at the project site:

- a. The engineer shall submit written certification that all grading has been completed in conformance with the approved plans, conditions of approval, and the Grading Regulations to the Department of Public Works and the Planning and Building Department's Geotechnical Engineer.
- b. The geotechnical consultant shall observe and approve all applicable work during construction and sign Section II of the Geotechnical Consultant Approval form, for submittal to the Planning and Building Department's Geotechnical Engineer and Current Planning Section.

Aesthetics:

14. The development of the water tanks shall employ colors and materials which blend in with, rather than contrast with, the surrounding soil and vegetative cover of the site. Materials shall absorb light (i.e., dark, rough textured materials). In grassland, or grassland/forest areas, all exterior materials shall be of the same earth and vegetative tones as the predominant colors of the site (as determined by on-site inspections). Highly reflective surfaces and colors are discouraged.

Permanent Stormwater Treatment Requirement:

15. As the project involves 12,230 sq. ft. of new impervious surface, the project shall comply with requirements for stormwater treatment as contained in Provision C.3 of the NPDES Municipal Regional Permit including, but not limited to, the following:
 - a. Prior to the final of the building permit for the project, the property owner shall coordinate with the Project Planner to enter into an Operation and Maintenance Agreement (O&M Agreement) with the County (executed by the Community Development Director) to maintain permanent stormwater treatment measures as approved by the Department of Public Works for the life of the project. The O&M Agreement shall provide County access to the property for inspection.
 - b. The property owner is responsible for submitting an Annual Report accompanied by a review fee to the County, as required by the O&M Agreement. The property owner is also responsible for the payment of an inspection fee for County inspections of the stormwater facility, conducted as required by the NPDES Municipal Regional Permit.

Other Planning Requirements:

16. Noise levels produced by proposed grading activities shall not exceed the 80-dBA level at any one moment. Grading activities generating noise levels that are greater than the ambient noise levels in the project area shall be limited to the hours from 7:00 a.m. to 6:00 p.m., Monday through Friday, and 9:00 a.m. to

5:00 p.m. on Saturdays. Noise-generating grading activities shall not occur at any time on Sundays, Thanksgiving and Christmas.

17. The construction contractor shall implement the following measures at all construction sites:
 - a. All exposed surfaces (e.g., parking areas, staging areas, soil piles, graded areas, and unpaved access roads) shall be watered two times per day when conditions are dry.
 - b. All haul trucks transporting soil, sand, or other loose material off-site shall be covered.
 - c. All visible mud or dirt tracked out onto adjacent public roads shall be removed. The use of dry power sweeping shall be prohibited.
 - d. All vehicle speeds on unpaved roads shall be limited to 15 miles per hour.
 - e. All parking areas and driveways to be paved shall be completed as soon as possible.
 - f. Idling times shall be minimized either by shutting equipment off when not in use or reducing the maximum idling time to 5 minutes (as required by the California Airborne Toxics Control Measure, Title 13, Section 2485, of the California Code of Regulations (CCR)). Clear signage shall be provided for construction workers at all access points.
 - g. All construction equipment shall be maintained and properly tuned in accordance with the manufacturer's specifications. All equipment shall be checked by a certified mechanic and determined to be running in proper condition prior to operation.
 - h. A publicly visible sign shall be posted with the telephone number and person to contact at the District regarding dust complaints. This person shall respond and take corrective action within 48 hours. The Bay Area Air Quality Management District's phone number shall also be visible to ensure compliance with applicable regulations.
18. On the first day of construction and prior to the start of any ground clearing, all workers shall participate in an environmental education training session given by a qualified biologist at the project site. A signature sheet shall be maintained to ensure that all personnel receive training. The education training shall include a description of the San Francisco garter snake, California red-legged frog, and western pond turtle and their habitat, the general provisions of the Endangered Species Act, the necessity of adhering to the Act to avoid penalty (for the San Francisco garter snake and the California red-legged frog only), and measures

implemented to avoid affecting the San Francisco garter snake, the California red-legged frog, and western pond turtle specific to the project and the work boundaries of the project.

19. During initial ground-disturbing activities in all project work areas, a District staff person who has completed the survey training for the California red-legged frog and is familiar with the identification, life history, habitat and behavior of the San Francisco garter snake will survey the impact area prior to starting work, and will be present throughout the ground disturbance period.

If the San Francisco garter snakes or the California red-legged frogs are observed on the project site at any time, the District shall contact California Department of Fish and Wildlife (CDFW) and United States Fish and Wildlife Service (USFWS) for further guidance. All work shall cease on the project site until the animal moves freely out of the construction zone or the District receives guidance from the resource agencies. If western pond turtles are observed within the project site, a qualified biologist and/or a District staff person who has received the environmental training shall relocate the turtle to a nearby area of suitable habitat. If a western pond turtle nest is discovered within the project site, all work within 50 feet of the nest shall cease and CDFW shall be contacted for guidance.

The District shall prepare a monitoring report detailing the above actions and findings for submittal to CDFW within sixty (60) days following completion of the project.

20. Vegetation removal shall be limited to the minimum necessary to construct the project. If feasible, project construction shall take place outside of the breeding bird season (the breeding bird season is generally February 15 to August 15). If work must be conducted during the breeding season, a qualified biologist shall conduct a pre-construction nesting bird survey throughout areas of suitable habitat located within 300 feet of the project site and no more than thirty (30) days prior to the initiation of site preparation, construction activity, tree trimming, or vegetation removal. If active bird nests are observed, a buffer zone shall be established around the nest to protect nesting adults and their young from construction disturbance. Buffer zones shall have a 300-foot radius for raptors (such as golden eagle and white-tailed kite), 100-foot radius for a passerine Species of Special Concern, and 25 to 50 feet (depending on species and nest location) for common bird species. The radius of the buffer zone shall be centered on the nest or nest tree/shrub. Smaller buffer zones may be established if it is determined by a qualified biologist in consultation with CDFW that the site conditions and/or species sensitivity to disturbance warrant a reduction in the buffer size. Additional monitoring may be required for buffer zones that are smaller than the typical size. Buffer zones shall be clearly delineated with stakes and flagging or construction fencing. No construction, material storage, staging, parking, or entrance shall be allowed in the buffer zone with the exception of biological monitors monitoring the

status of the nests. The buffer zone shall be maintained until the young are fledged and foraging independently, as determined by a qualified biologist.

21. No more than thirty (30) days prior to the initiation of site preparation, construction activity, vegetation removal, or tree trimming, a qualified biologist shall inspect the proposed staging area and/or access road and adjacent areas within 50 feet for woodrat nests. An exclusion zone shall be erected around any potentially affected woodrat nest using a temporary fence that does not inhibit the natural movements of wildlife (such as steel T-posts and a single strand of yellow rope or similar materials). If woodrat nests cannot be avoided during construction, woodrats shall be relocated by live trapping and relocated to nearby temporary shelters as a release site. An inverted half wine barrel containing woody debris from the impacted nest shall provide the temporary shelter. The plan to live trap and relocate woodrats shall be approved by CDFW.
22. No more than ten (10) days prior to the initiation of site preparation, construction activity, vegetation removal, or tree trimming, a qualified biologist shall inspect the proposed road alignment, staging area, and/or access road and adjacent areas within 25 feet for badger dens. If an active den is located, a qualified biologist shall determine if the burrow is occupied by using either a burrow camera, track plates, or direct observations to determine the contents of the burrow. If the den is determined to be an active natal den, work shall cease within 100 feet of the burrow and either the construction moved to avoid impacts to the den if feasible or have a qualified biologist monitor the burrow until the young have dispersed. If the burrow is occupied by an adult badger without young, the burrow shall be hand-excavated to allow the badger to escape. If the burrow is not occupied by a badger, the burrow shall be sealed with a hand shovel.
23. Prior to construction, fencing shall be installed around blue wild rye grassland to prevent encroachment of equipment or construction personnel into sensitive habitat. Invasive, non-native plant species that occur adjacent to the work area shall be removed or controlled to prevent encroachment into adjacent habitats.
24. If mature trees or snags are removed during the bat breeding season (April 1 through August 31), a qualified bat biologist shall inspect trees for potential roost sites. If no potential roost sites are found, no additional mitigation would be necessary. If bat roosts are found, direct disturbance to the roost shall be avoided during the breeding season. If a potentially suitable roost tree is removed in the non-breeding season, a qualified biologist shall inspect the tree prior to removal to ensure that bats are not occupying the roost. If bats are determined to be present, tree removal shall be suspended until the bats have left. Netting can be placed over the entrance of a roost site to allow bats to emerge but not return. Partially exposing a potential roost site (such as removing a tree limb or bark) after the bats have left can also make the roosts unattractive to bats so they will not return. Exclusion or partial exposure of a roost before tree removal shall be monitored by a qualified biologist.

25. Implementation of the following measures would reduce potential impacts to cultural and historical resources including buried and unknown archaeological and paleontological resources to a less than significant level:
- a. If any commonly recognized sensitive cultural resource such as human formed artifacts, including projectile points, grinding stones, bowls, baskets, historic bottles, cans, or trash deposits are encountered during project construction, every reasonable effort shall be made to avoid the resource. Work shall stop within 100 feet of the object(s) and the contractor shall contact the District. No work shall resume within 100 feet until a qualified cultural and/or historical resources expert can assess the significance of the find.
 - b. A reasonable effort shall be made by the District to avoid or minimize harm to the discovery until significance is determined and an appropriate treatment can be identified and implemented. Methods to protect finds include fencing and covering with protective material such as culturally sterile soil or plywood.
 - c. If vandalism is a threat, 24-hour security shall be provided.
 - d. Construction outside of the find location can continue during the significance evaluation period and while mitigation for cultural and/or historical resources is being carried out, only if a qualified cultural and/or historical resources expert is present on-site monitoring any additional subsurface excavations within 100 feet of the find.
 - e. If a resource cannot be avoided, a qualified cultural and/or historical resources expert shall develop an appropriate Archaeological or Paleontological Action Plan for treatment to minimize or mitigate the adverse effects. The District shall not proceed with reconstruction activities within 100 feet of the find until the Action Plan has been reviewed and approved by the District General Manager.
 - f. Findings will be detailed in a professional report in accordance with current professional standards. Any non-grave associated artifacts will be curated with an appropriate repository.
 - g. Project documents shall include a requirement that project personnel shall not collect cultural and/or historical resources encountered during construction. This measure is consistent with Federal Guideline 36 Code of Federal Regulations 800.13(a) for invoking unanticipated discoveries.
26. If human remains are encountered, all work within 100 feet of the remains shall cease immediately and the contractor shall contact the District. The District shall contact the San Mateo County Coroner to evaluate the remains, and follow the

procedures and protocols set forth in Section 15064.5(e) of the CEQA Guidelines. No further disturbance of the site or any nearby area reasonably suspected to overlie adjacent remains shall occur until the County Coroner has made a determination of origin and disposition, which shall be made within two (2) working days from the time the Coroner is notified of the discovery, pursuant to State Health and Safety Code Section 7050.5 and Public Resources Code Section 5097.98. If the remains are determined to be Native American, the Coroner will notify the Native American Heritage Commission (NAHC) within 24 hours, which will determine and notify the Most Likely Descendant (MLD). The MLD may recommend within 48 hours of their notification by the NAHC the means of treating, with appropriate dignity, the human remains and grave goods. In the event of difficulty locating an MLD or failure of the MLD to make a timely recommendation, the human remains and grave goods shall be reburied with appropriate dignity on the property in a location not subject to further subsurface disturbance.

Department of Public Works

27. The property owner shall submit a permanent stormwater management plan in compliance with the County's Drainage Policy and NPDES requirements for review and approval by the Department of Public Works.
28. The property owner shall have prepared, by a registered civil engineer, a drainage analysis of the project and submit it to the Department of Public Works for review and approval. The drainage analysis shall consist of a written narrative and a plan. The flow of the stormwater onto, over, and off the property shall be detailed on the plan and shall include adjacent lands as appropriate to clearly depict the pattern of flow. The analysis shall detail the measures necessary to certify adequate drainage. Post-development flows and velocities shall not exceed those that existed in the pre-developed state. Recommended measures shall be designed and included in the street improvement plans and submitted to the Department of Public Works for review and approval.
29. No proposed construction work within the County right-of-way shall begin until County requirements for the issuance of an encroachment permit, including review of the plans, have been met and an encroachment permit issued.

Building Inspection Section

30. Building permit(s) are required for the water tanks, driveway widening, turnouts, turnarounds, adding a fire hydrant, and extension of culverts (BLD 2011-00958).
31. Stormwater Regulated Site (SWRS) Inspections Required: The property owner shall arrange (including payment of applicable fees) for the Building Inspection Section to conduct monthly erosion and sediment control monitoring from all

grading and construction activities approved under this permit, during the wet season (October 1 through April 30).

Cal-Fire

32. Access roads shall be 20 feet wide, incorporating an all-weather surface, and able to support a fire apparatus weighing 75,000 lbs. Grades over 15% slope shall be paved and no grade shall be over 20% slope. When gravel roads are used, it shall use a Class 2 base or equivalent compacted to 95%. Gravel road access shall be certified by an engineer as to the compaction and weight it will support. Prior to the issuance of a building permit for this project, the property owner shall demonstrate compliance with the above requirements.
33. Remote reflective address compliant with San Mateo County Fire Standards at the driveway entrances shall be added to the property. There shall be contrasting illuminated address on the residence.

RJB:fc – RJB0756_WFU.DOCX

L:_PlanningLayer\GIS\Vicinity Map\PLN14-46.mxd

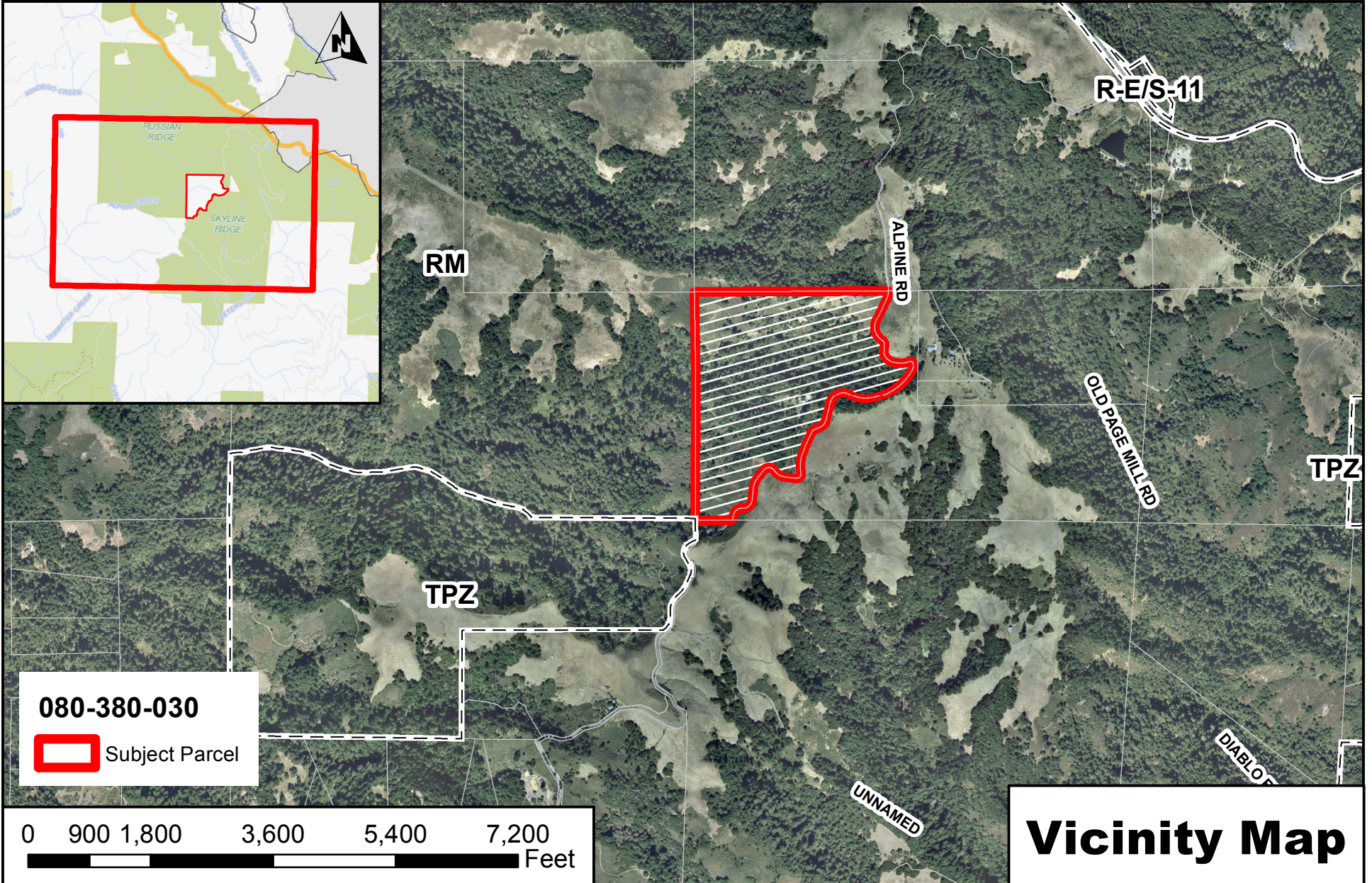

080-380-030

 Subject Parcel

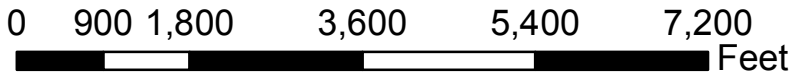

Vicinity Map

San Mateo County Planning Commission Meeting

Owner/Applicant: _____

Attachment: _____

File Numbers: _____

Created By: jhawk Path: G:\Projects\Russian_Ridge_SilvaProperty\SitePlan_3_2012.mxd

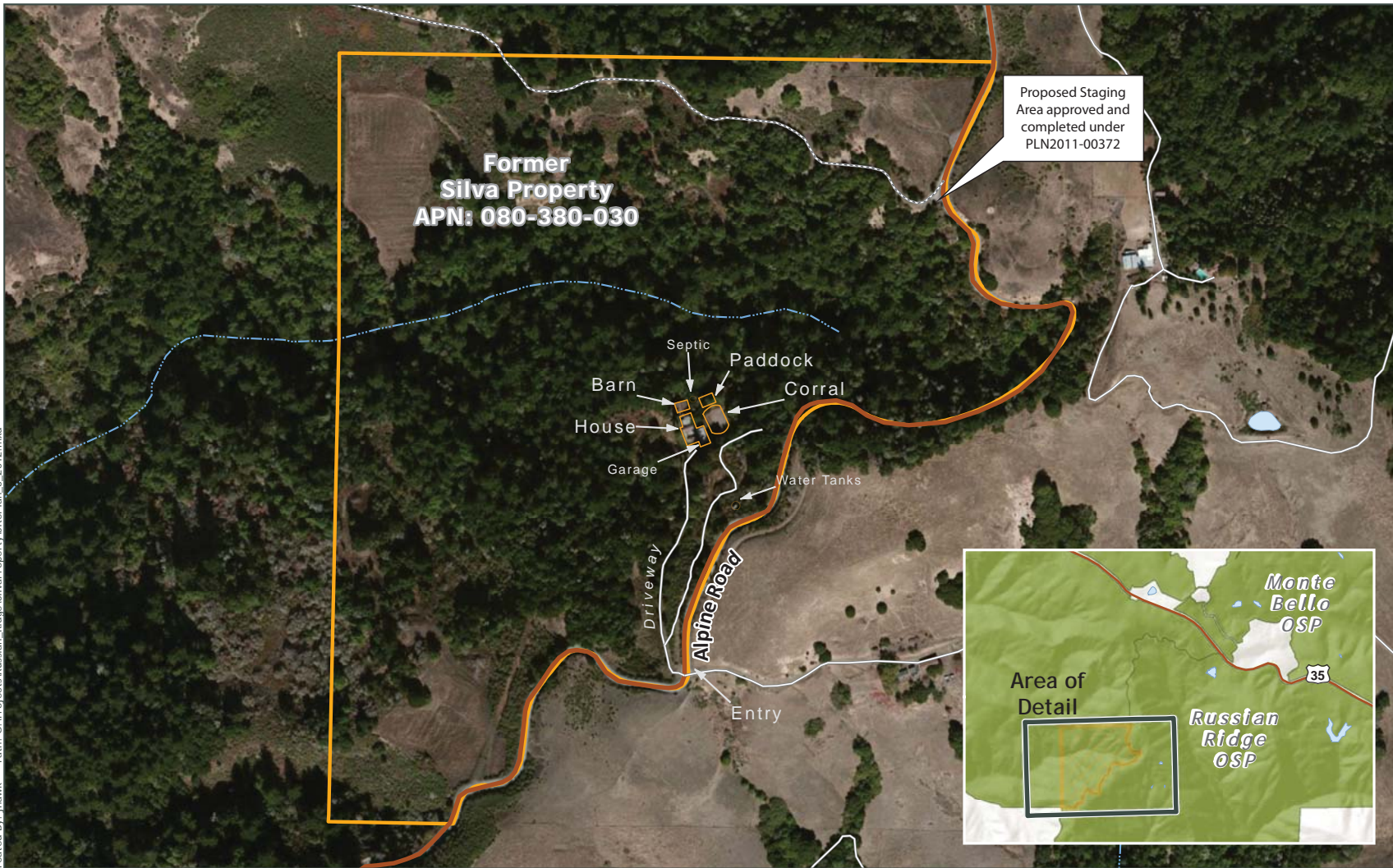

Site Plan: 5755 Alpine Rd, La Honda, CA (APN: 080-380-030)

 Former Silva Property

Midpeninsula Regional
Open Space District
(MROSD)



March, 2012



While the District strives to use the best available digital data, this data does not represent a legal survey and is merely a graphic illustration of geographic features.

San Mateo County Planning Commission Meeting

Owner/Applicant: _____



Attachment: _____

File Numbers: _____

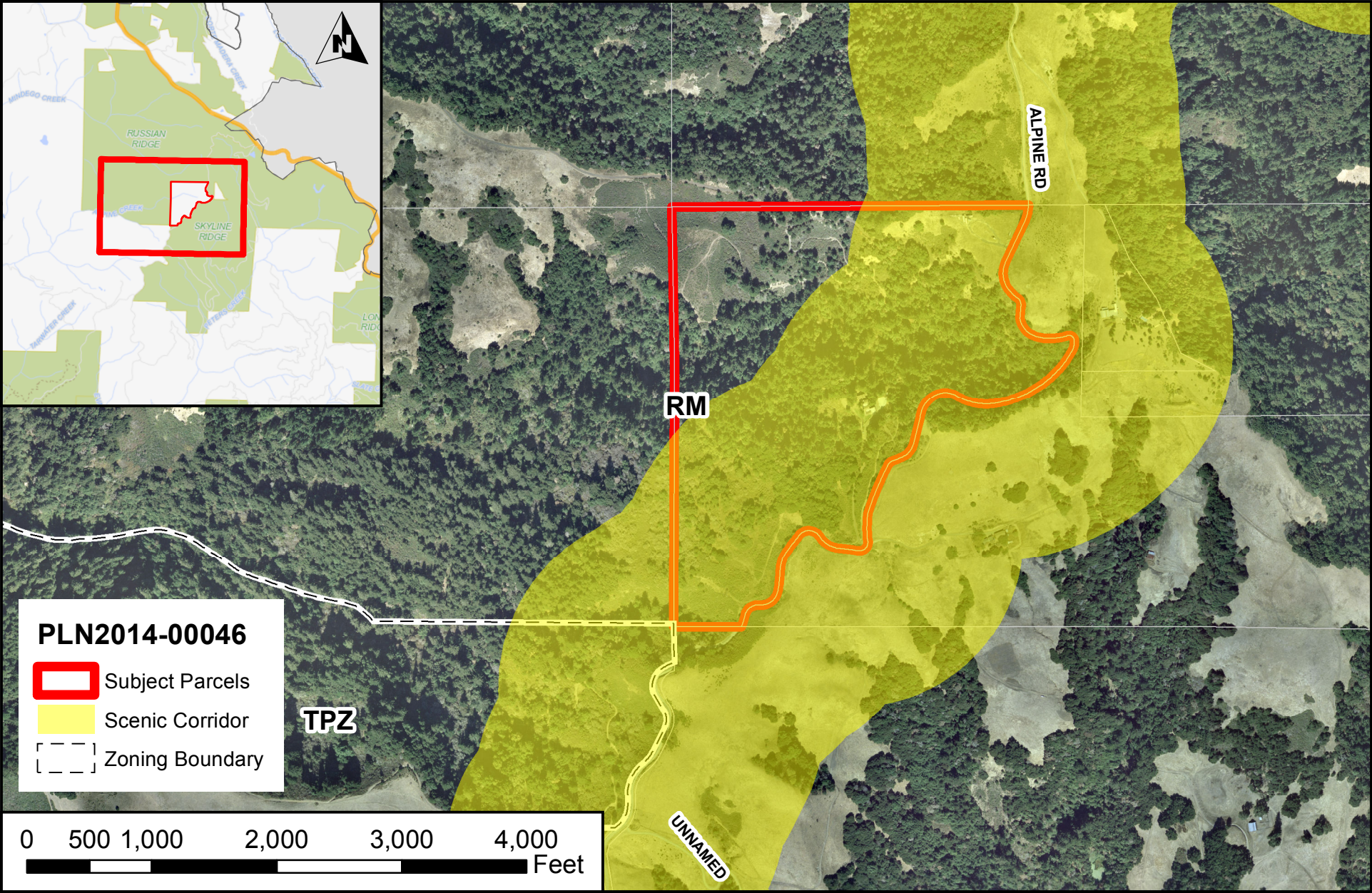
L:_PlanningLayer\GIS\Vicinity Map\PLN14-46.mxd



PLN2014-00046

-  Subject Parcels
-  Scenic Corridor
-  Zoning Boundary

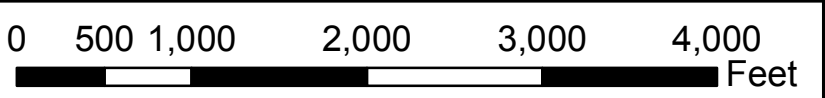

San Mateo County Planning Commission Meeting

Owner/Applicant: _____

Attachment: _____

File Numbers: _____

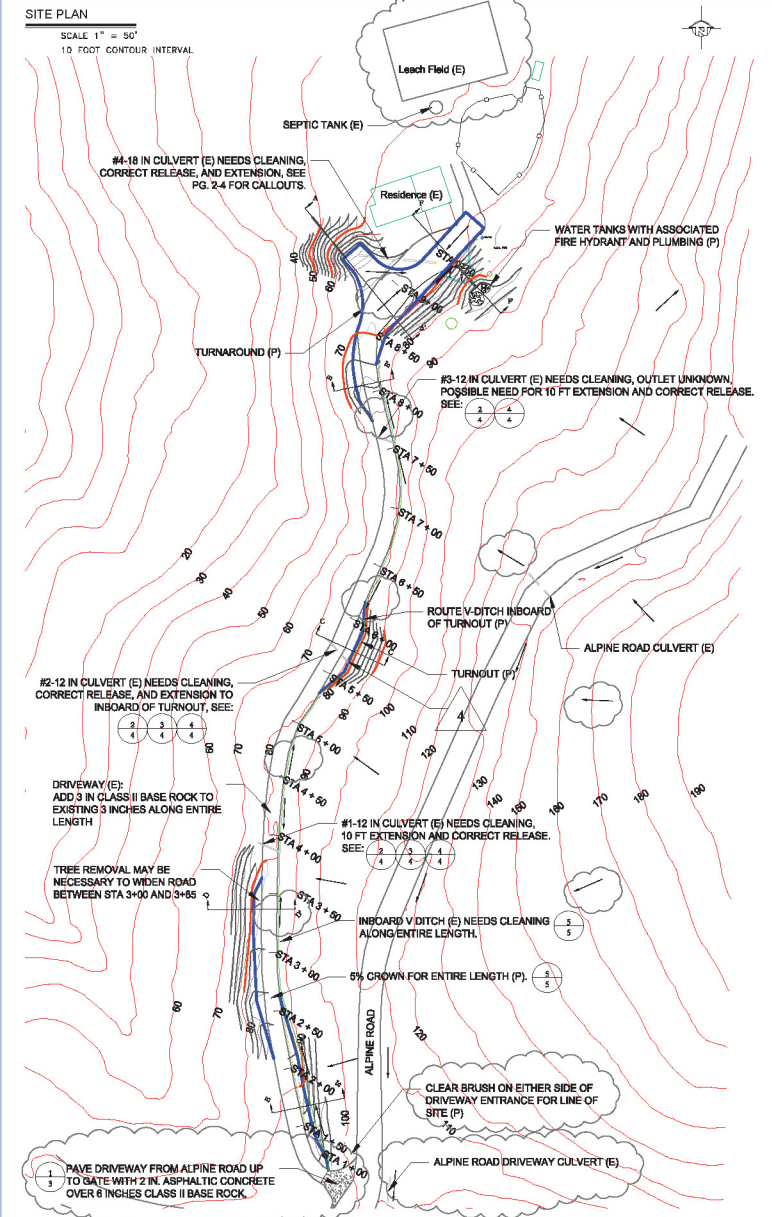
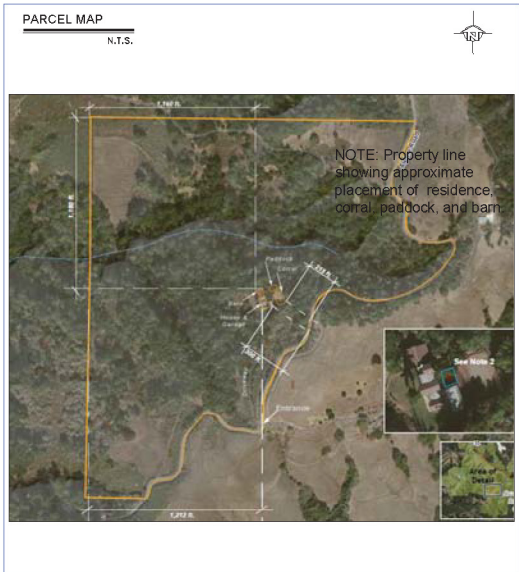

- GENERAL NOTES (For Key See Pg. 4)**
- EXCAVATION AND BACKFILL**
- The Geotechnical Engineer should be notified at least (4) working days prior to any grading or foundation excavating so the work in the field can be coordinated with the grading contractor, and arrangements for testing and observation can be made. The recommendations of this report are based on the assumption that the geotechnical engineer will perform the required testing and observation during grading and construction. It is the owners responsibility to make the necessary arrangements for these services.
- Geotechnical Engineer of Record:
Butano Geotechnical Engineering Inc.
231 Green Valley Road Suite E
Fresno CA, 95019
Phone: (831) 724 - 2612
- The contractor shall verify all dimensions and elevations in the field. Any variations from the design are to be immediately brought to the attention of the design engineer.
 - After the earthwork operations have been completed and the soil engineer has finished their observation of the work, no further earthwork operations shall be performed except with the approval of and under the observation of the geotechnical engineer.
 - The contractor shall be responsible for protecting cut slopes and exposed soil during construction.
- DRAINAGE:**
- The driveway should be crowned with 5% side slopes.
 - Inboard ditches should be cleaned of debris and maintained on an annual basis.
- EROSION CONTROL:**
- Between October 15th and April 15th, exposed soil shall be protected from erosion at all times. Hay bales, filter berms, or other means shall be employed to prevent turbid runoff to the drainage area or to adjoining properties.
 - All areas exposed during construction, if not permanently landscaped per plans, shall be protected by mulching and/or planting of the following erosion control mix, at a rate of 35 pounds per acre:
- | | |
|---------------------------------|-------|
| Blando Bromo | 50% |
| Rose Clover (Pellet inoculated) | 36% |
| Cresting Red Fescue | 15% |
| Zorro Annual Fescue | Trace |
| Wildflowers | Trace |
- Unnecessary grading and disturbing of soil shall be avoided.
 - Any excess material shall be disposed of off-site or stockpiled in a manner to avoid runoff onto adjoining properties.
 - Any material stockpiled during construction shall be covered with plastic.
 - Use B.M.P. to erosion control construction bench. This will include straw wattles placed at downslope edge of construction bench.
 - Place straw waddle or other approved sediment control measure along base of grade.
 - Place approved erosion control blanket on all slopes greater than 2:1 (H:V).
- REQUIRED INSPECTION:**
- Observation and testing of all engineered fill.
- APPROVED:**
- Engineered fill (on-site and imported) to be placed at a minimum of 90% relative compaction. The upper 6 inches of subgrade and all aggregate base/rock to be compacted to a minimum of 95% relative compaction.

CUT AND FILL:

TOTAL CUT:
287 CUBIC YARDS

TOTAL FILL:
618 CUBIC YARDS
-183 CUBIC YARDS CLASS II BASE ROCK
-268 CUBIC YARDS IMPORTED ENGINEERED FILL
-167 CUBIC YARDS ENGINEERED FILL FROM CUT

Culvert Loading Analysis

Culvert #	Culvert Diameter (in)	Existing Depth of Embedment (in)	Minimum Allowable Depth of Embedment (in)	Adequate (yes/no)
1	12	12	12	Yes
2	12	18	12	Yes
3	12	12	12	Yes
4	18	12	12	Yes

San Mateo County Planning Commission Meeting

Owner/Applicant:
File Numbers:

Attachment:

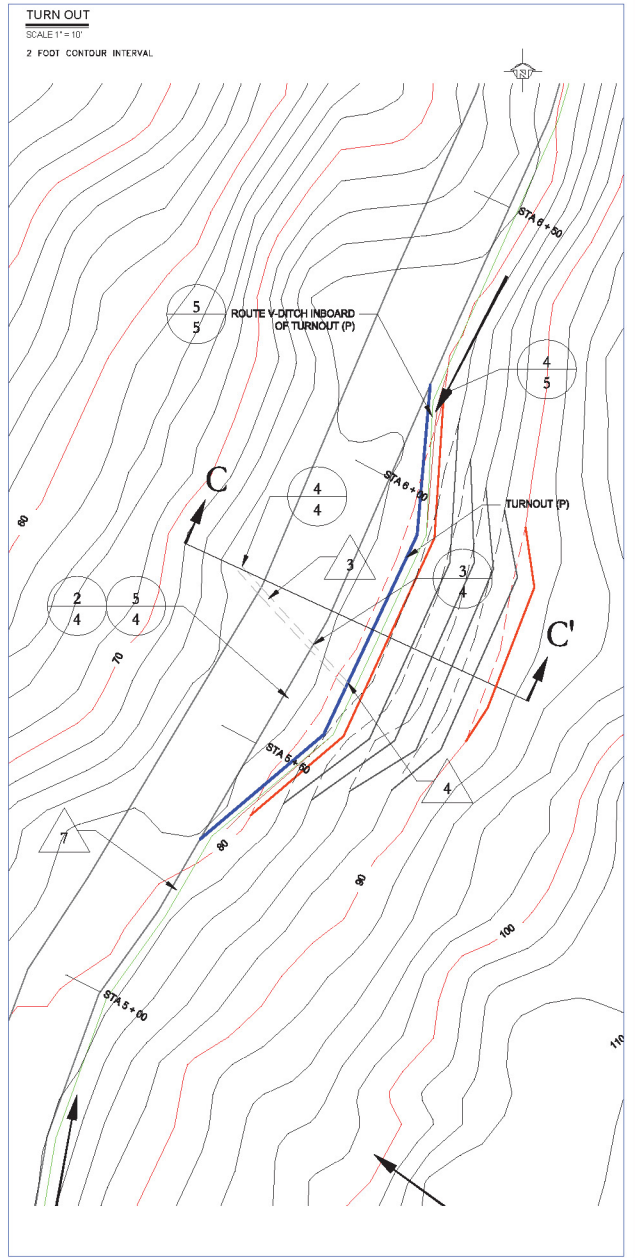
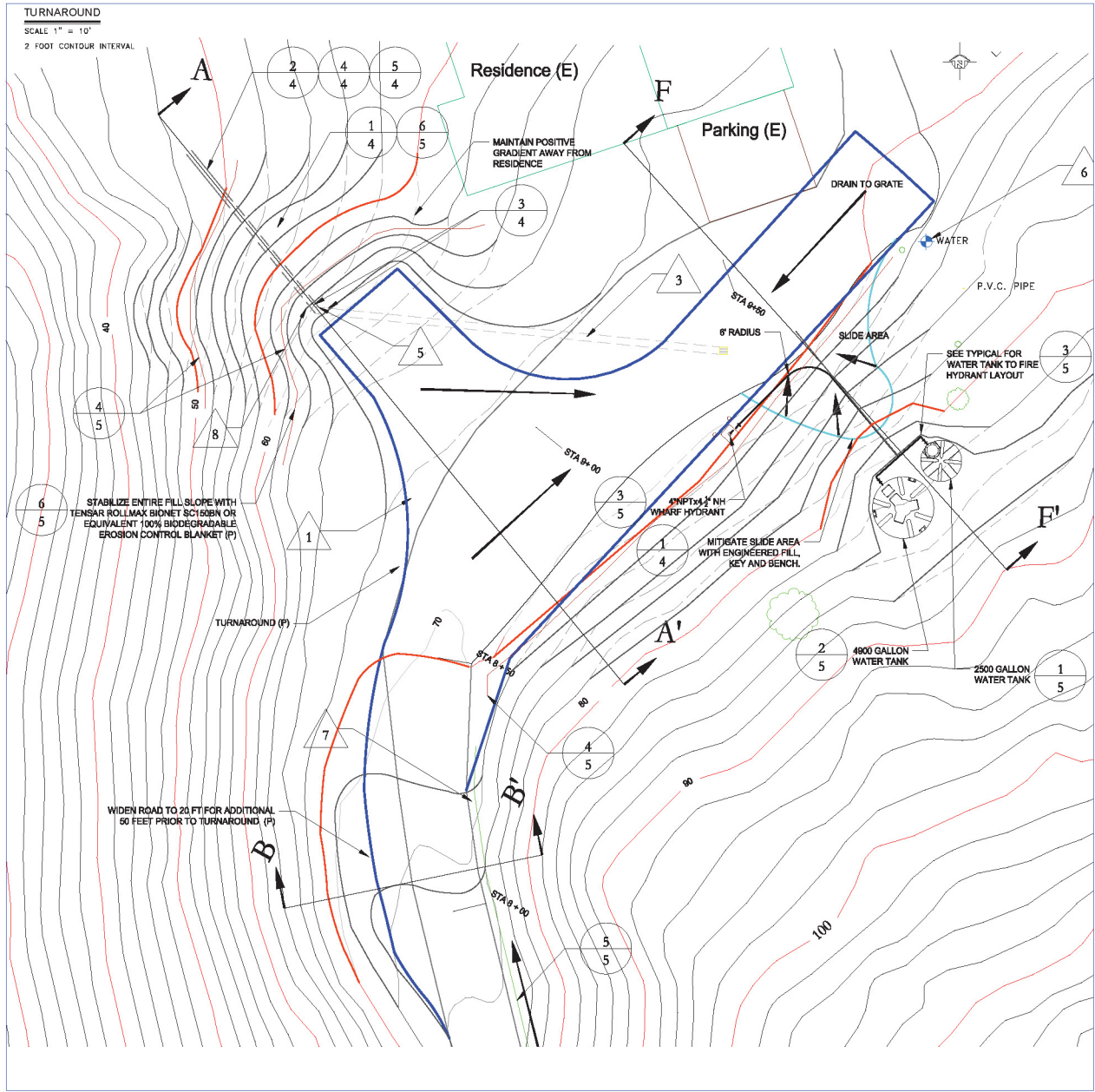

San Mateo County Planning Commission Meeting

Owner/Applicant: _____
Attachment: _____
File Numbers: _____

PROFILE

SCALE: 1" = 30'

GRADIENT %:

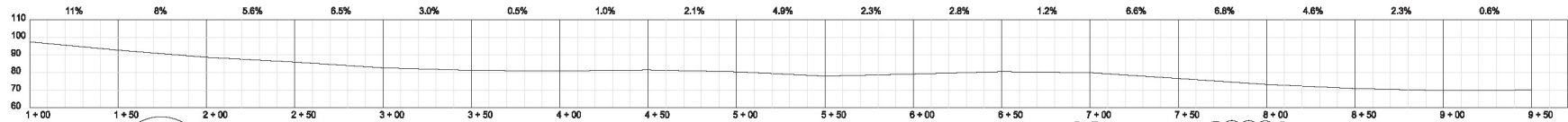

NOTE: Driveway is currently surfaced with 3 in of aggregate baserock. The existing baserock should be compacted to a minimum of 95% relative compaction and an additional 3 in of class II aggregate baserock should be added and compacted to 95% relative compaction. 6 in. of class II aggregate baserock should continue up to the county road, 2" of asphaltic concrete should be placed on the driveway entrance from Alpine Road to the entrance gate.

TYPICAL DRIVEWAY CROSS SECTION:
N.T.S.

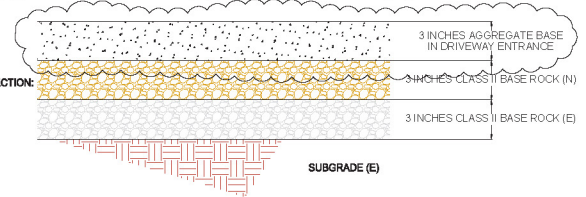

1/3 Driveway Cross Sections

CROSS SECTIONS - EXISTING/PROPOSED

SCALE: 1" = 20'

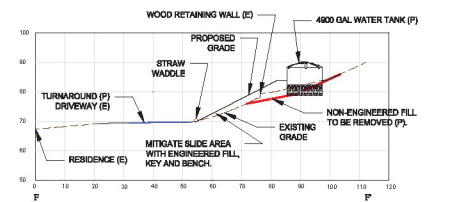
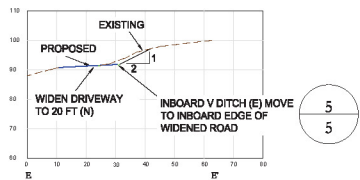
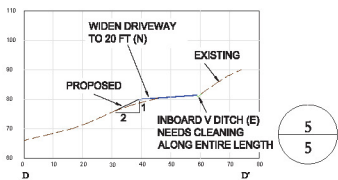
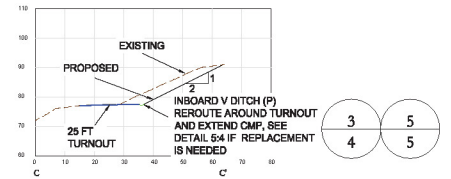
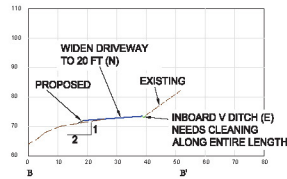
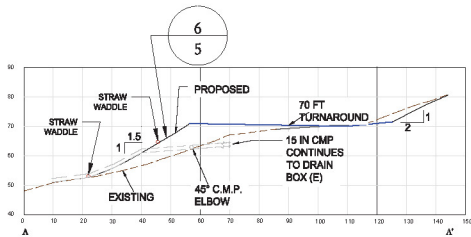

San Mateo County Planning Commission Meeting

Owner/Applicant: _____

File Numbers: _____

Attachment: _____

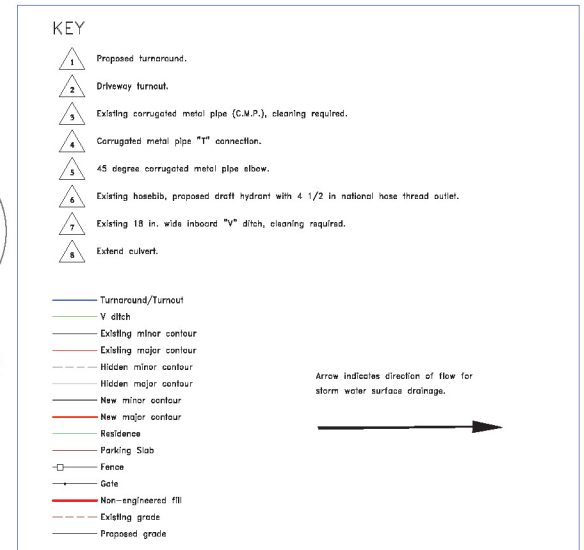
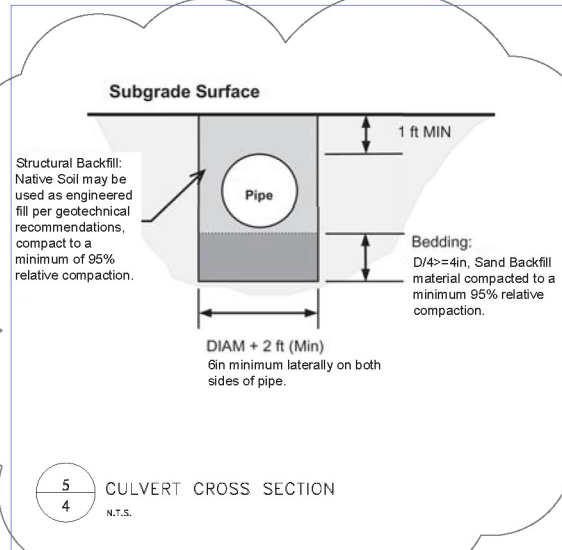
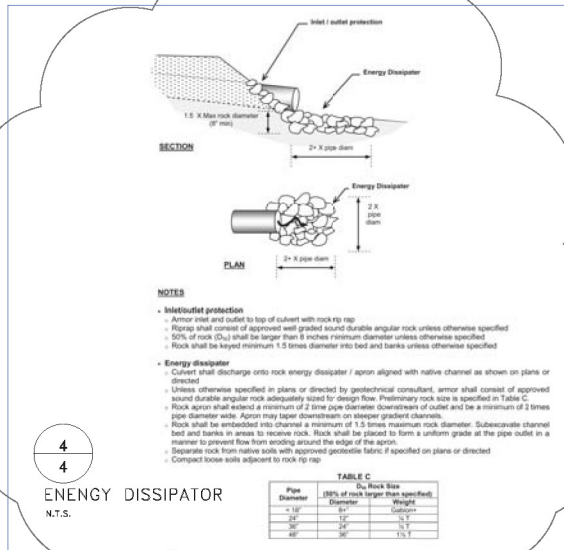
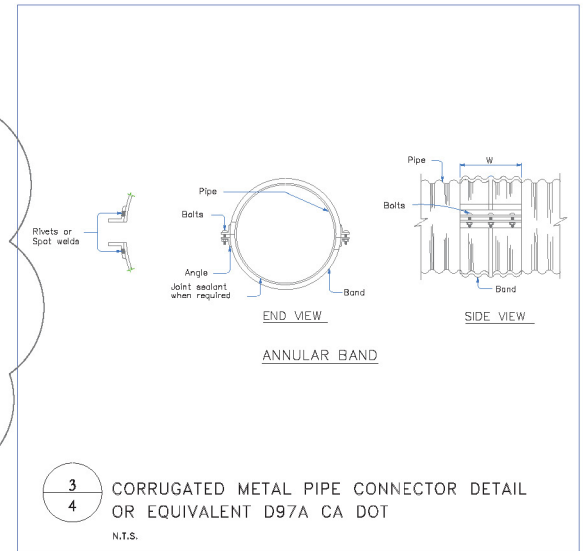
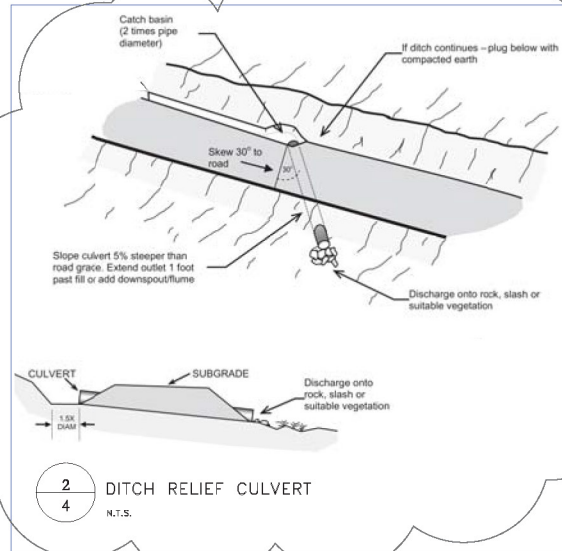
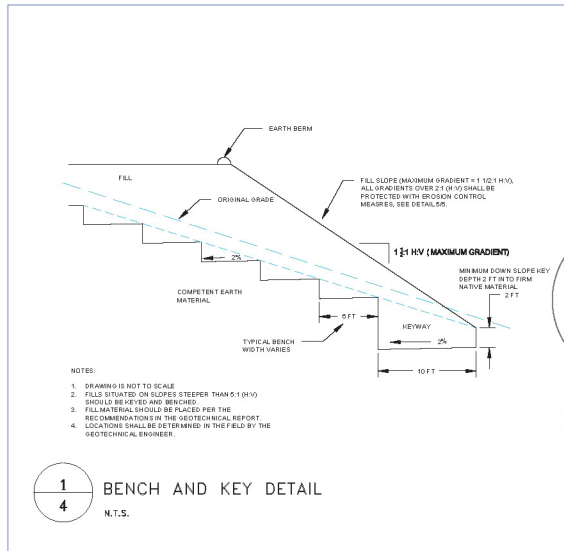

San Mateo County Planning Commission Meeting

Owner/Applicant: _____

File Numbers: _____

Attachment: _____

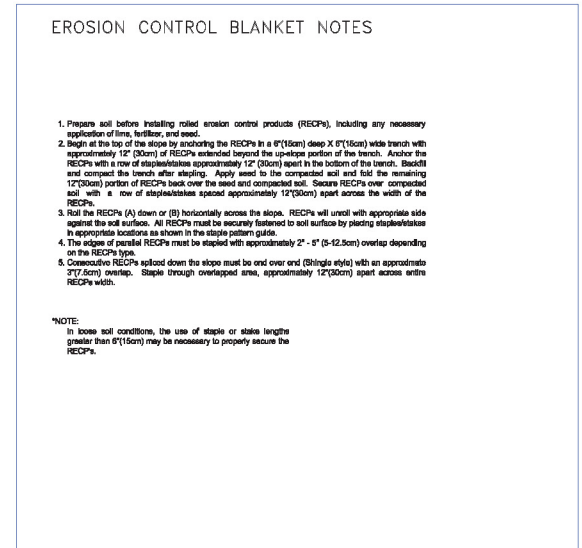
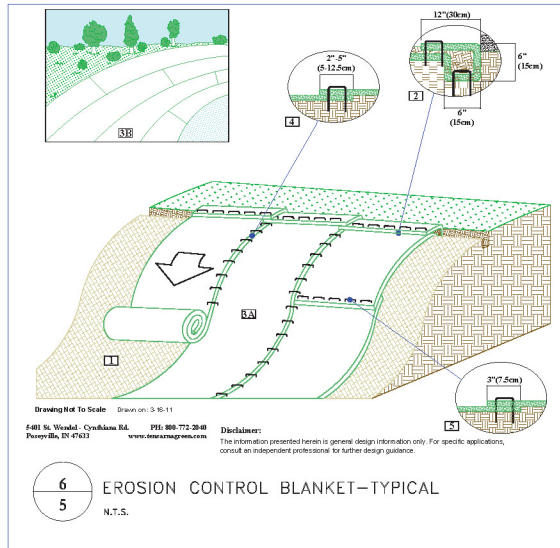
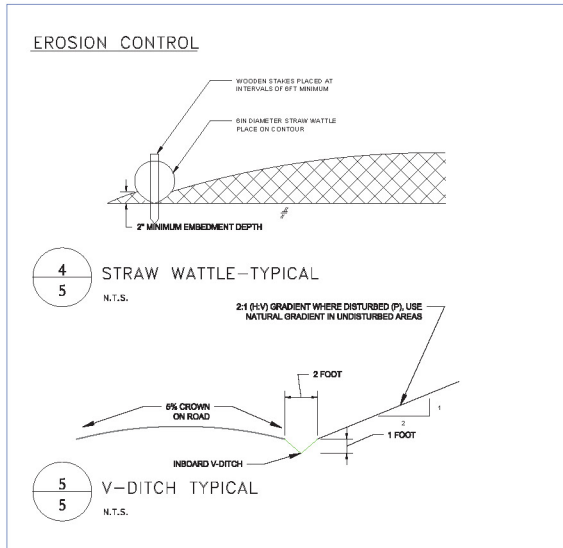
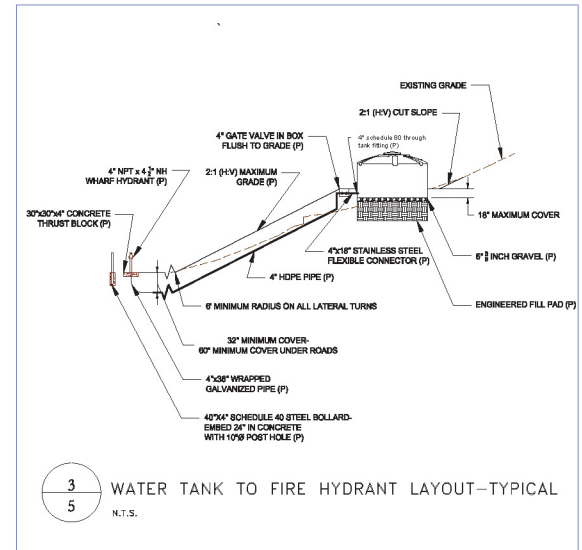
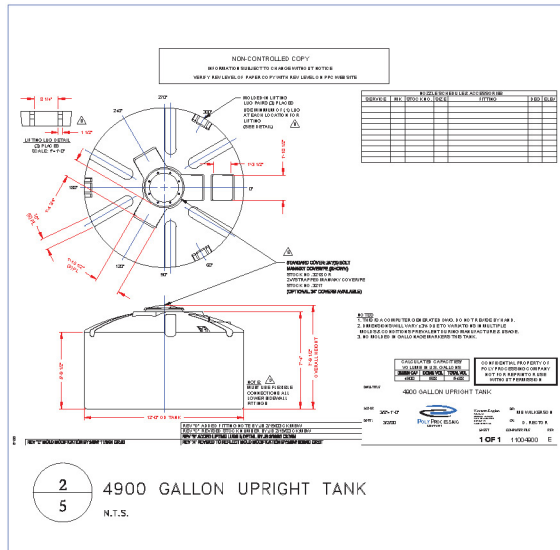
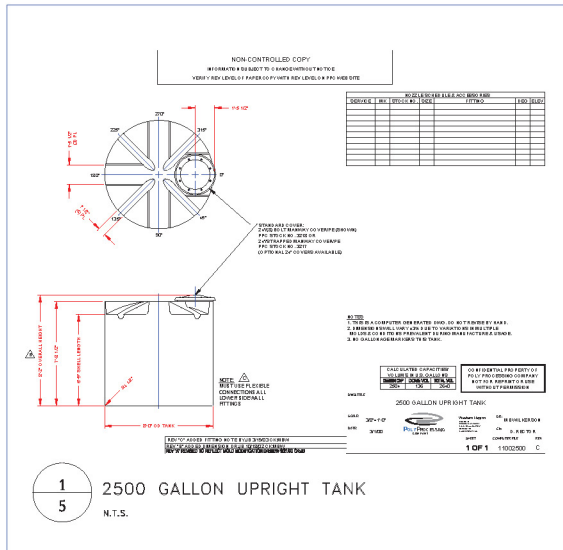

San Mateo County Planning Commission Meeting

Owner/Applicant:

File Numbers:

Attachment: